

REPAIRED BY : DATE	 TENRI LIQUID CRYSTAL DISPLAY GROUP SHARP CORPORATION SPECIFICATION	SPEC No. LD-7Y04B
		FILE No.
APPROVED BY : DATE		Issue: Nov .30 .1995
		PAGE : 16 pages
		APPLICABLE GROUP Tenri Liquid Crystal Display Group

DEVICE SPECIFICATION FOR
TFT-LCD Module
MODEL No.
LQ9PS01

CUSTOMER'S APPROVAL

DATE _____

BY _____

Presented

BY *H. Fukuoka*

H. FUKUOKA

Department General Manager

Engineering Department 2

TFT LCD Development Center

TENRI LIQUID CRYSTAL DISPLAY GROUP

SHARP CORPORATION

1. Application

This specification applies to color **TFT-LCD** module, LQ9PS01.

2. Overview

This module is a color active **matrix LCD module** incorporating amorphous silicon **TFT** (Thin Film Transistor). It is composed of a color **TFT-LCD** panel, driver **ICs**, control circuit and power supply circuit. Graphics and texts can be displayed on a **800 × 3 × 600 dots panel** with 262,144 colors by supplying 18 bit data **signals**(6bit/color), four timing **signals**, +5V DC supply voltage for **TFT-LCD** panel driving.

The **backlight** system is not installed in this module and the **TFT-LCD** panel used for this model is a **high-transmission** and **higher-color-saturation** type. Therefore, this module is suitable for the projection-type multimedia applications.

Horizontal and vertical display reversal function is built in this module for the projection use,

[Features]

- ◎ Low power consumption.
- ◎ High transmissivity
- ◎ Wide color reproduction range
- ◎ Mechanical compatibility with the VGA models:LQ9P031

3. Mechanical Specifications

Parameter	Specifications	unit
Display size	21(8.4") Diagonal	cm
Active area	170.4 (H) × 127.3 (V)	mm
Pixel format	800 (H) × 600 (V)	pixel
	(1 pixel=R+G+B dots)	
Pixel pitch	0.213 (H) × 0.213 (V)	mm
Pixel configuration	R,G,B vertical stripe	
Display mode	Normally white	
Unit outline dimensions	242.5(W)× 179.4(H) × 8.2(D)	mm
Mass	380 ± 10	g
Surface treatment	Hard-coating 2H (clear)	

Outline dimensions is shown in Fig.1

4. Input Terminals

4-1. TFT-LCD panel driving

CN1 Used connector:DF9MA-41P- 1 V (Hirose Electric Co., Ltd.)

1		41	Corresponding connector:
2		40	DF9□-41S-1V (Hirose Electric Co., Ltd.)

CN1 pin arrangement from module

DF9M-41S-1R ("), □ is blank. M,A, or B. 【Note1】

(Transparent view)

Pin No.	Symbol	Function	Remark
1	GND		
2	CK	Clock signal for sampling each data signal	
3	GND		
4	GND		
5	Hsync	Horizontal synchronous signal	【Note2】
6	Vsync	Vertical synchronous signal	【Note2】
7	GND		
8	R0	R E D data signal (LSB)	
9	RI	R E D data signal	
10	R2	R E D data signal	
11	R3	R E D data signal	
12	R4	R E D data signal	
13	R5	R E D data signal (MSB)	
14	GND		
15	GND		
16	GND		
17	G0	G R E E N data signal (LSB)	
18	G1	G R E E N data signal	
19	G2	G R E E N data signal	
20	G3	G R E E N data signal	
21	G4	G R E E N data signal	
22	G5	G R E E N data signal (MSB)	
23	GND		
24	GND		
25	GND		
26	B0	B L U E data signal (LSB)	
27	B1	B L U E data signal	
28	B2	B L U E data signal	
29	B3	B L U E data signal	
30	B4	B L U E data signal	
31	B5	B L U E data signal (MSB)	
32	GND		
33	GND		
34	GND		
35	ENAB	Signal to settle the horizontal display position	【Note3】
36	Vcc	+5.0V power supply	
37	Vcc	+5.0V power supply	
38	R/L	Signal to settle the horizontal display reverse	【Note4】
39	u/D	Signal to settle the vertical display reverse	【Note5】
40	GND		
41	GND		

※The shielding case is connected with GND.

【Note1】 DF9M series connector has the reinforced metal fittings as shown in right drawing and when connectors are coupled together, the metal fittings of each connector are connected perfectly. Since the fittings of module-side are connected to GND in the module, GND line can be reinforced by using DF9M connector with metal fittings connected to GND at user-side.
 DF9M-41S-1R : Cable type connector

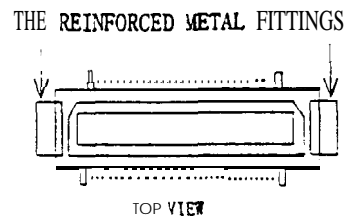

【Note2】 The polarity of both synchronous signals are negative.

【Note3】 The horizontal display start timing is settled in accordance with a rising timing of ENAB signal. In case ENAB is fixed "Low", the horizontal start timing is determined as described in 7-2. Don't keep ENAB "High" during operation.

【Note 4】

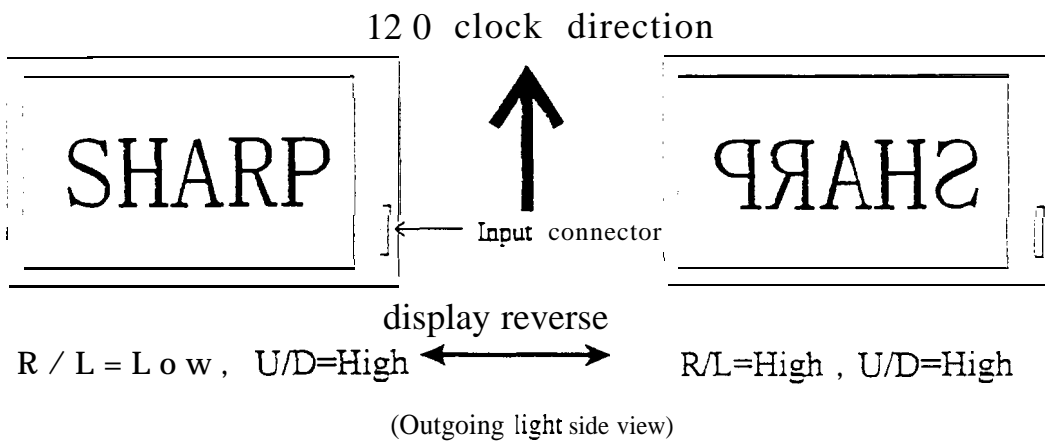

【Note 5】

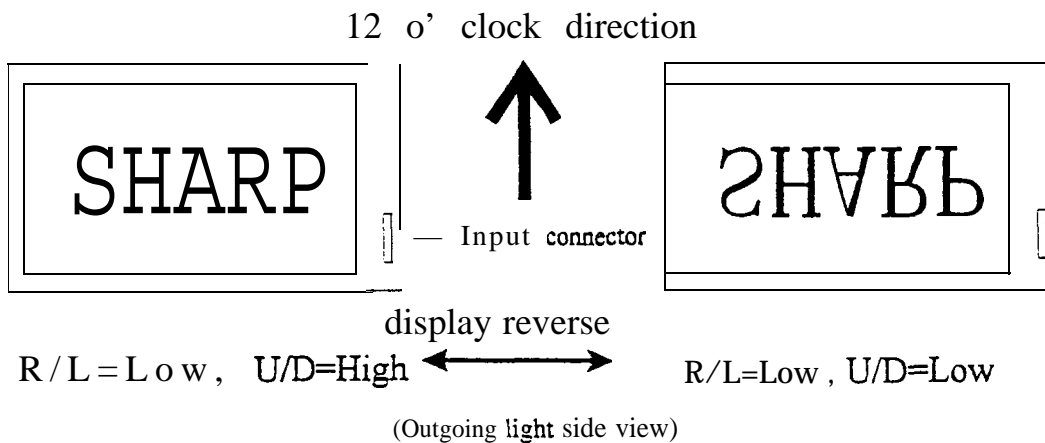

5. Absolute Maximum Ratings

Parameter	Symbol	Condition	Ratings	unit	Remark
Input voltage	V_I	$T_a=25^\circ\text{C}$	$-(3.3 \sim V_{cc} + 0.3)$	V	【Note1】
+5V supply voltage	V_{cc}	$T_a=25^\circ\text{C}$	$0 \sim +6.0$	v	
Storage temperature	T_{stg}	-	$-25 \sim +60$	"c	【Note2】
Operating temperature (Ambient)	T_{opa}	-	$0 \sim +50$	$^\circ\text{C}$	
Panel surface temperature	T_p	-	$0 \sim +60$	$^\circ\text{C}$	
Wave length of light source	λI	-	$\cong 400$	nm	
Illumination intensity of light source	I	-	$\cong 300,0(00)$	lx	【Note3】

【Note1】 CK,R0~R5,G0~G5,B0~B5,Hsync,Vsync,ENAB,R/L,U/D

【Note2】 The temperature at any points of the module, especially on the TFT-LCD panel, should not exceed this specification value.

Humidity : 95%RH Max. at $T_a \leq 40^\circ\text{C}$.

Maximum wet-bulb temperature at 39°C or less at $T_a > 40^\circ\text{C}$.

No condensation.

【Note3】 The illumination intensity at any points on the panel should not exceed this specification value. The light source should be placed at the incident-light side.

Measurement point : panel surface

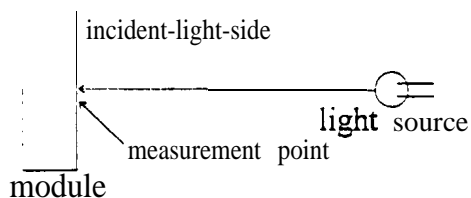

6. Electrical Characteristics

Ta=25°C

Parameter	Symbol	Min.	Typ.	Max.	unit	Remark	
i- 5V	Supply voltage	V _{CC}	+4.5	+5.0	+5.5	v	【Note1】
	Current dissipation	I _{CC}		240	380	mA	【Note2】
Permissive input ripple voltage	V _{RP}	-	-	100	mVp-p	V _{CC} =+5.0V	
Input voltage (Low)	V _{IL}	!	-	0.3V _{CC}	V	[Note31]	
Input voltage (High)	V _{IH}	0.7V _{CC}	-	-	V		
Input current (low)	I _{IL1}	-	-	1.0	μA	V _I =0V 【Note4】	
	I _{IL2}	75	1	1500	μA	V _I =0V 【Note5】	
	I _{IL3}	-	-	5.0	μA	V _I =0V 【Note6】	
Input current (High)	I _{IH1}	-	-	1.0	μA	V _I =V _{CC} 【Note4】	
	I _{IH2}	-	-	5.0	μA	V _I =V _{CC} 【Note5】	
	I _{IH3}	3	-	60	μA	V _I =V _{CC} 【Note6】	

【Note1】

V_{CC}-turn-on conditions

0 < t1 ≤ 10ms

0 < t2 ≤ 50ms

0 < t3 ≤ 1s

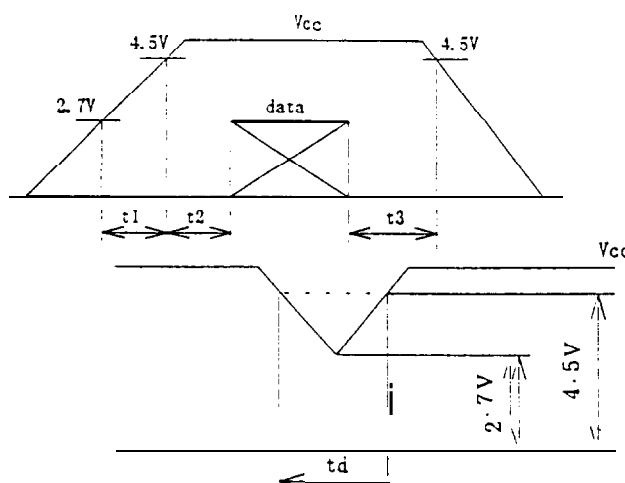

V_{CC}-dip conditions

1) 2.7V ≤ V_{CC} < 4.5V “
td ≤ 10ms

2) V_{CC} < 2.7V

V_{CC}-dip conditions should also follow the V_{CC}-turn-on conditions

【Note2】 The typical value of I_{CC} is measured in the following condition.

V_{CC}=+5.0V

64-gay-bar pattern.

All of the timing parameters are typical value.

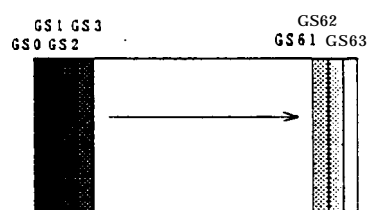

[Note31] CK,R0~R5,G0~G5,B0~B5,Hsync,Vsync,R/L,U/D,ENAB

[Note4] CK,R0~R5,G0~G5,B0~B5,Hsync,Vsync

[Note5] R/L,U/D

[Note6] ENAB

7. Timing Characteristics of input signals

Timing diagrams of input signal are shown in Fig.2.

7-1. Timing characteristics

Parameter		Symbol	Min.	Typ.	Max.	unit	Remark
Clock	Frequency	1/Tc	38.0	40.0	42.0	MHz	
	High time	Tch	5	-	-	ns	
	Low time	Tcl	5	-	-	ns	
	Duty ratio	TH/T	40	50	60	%	
Data	Setup time	Tds	3	-	-	ns	
	Hold time	Tdh	10	-	-	ns	
Horizontal sync. signal	Cycle	TH	20.8	26.4	-	μs	
			832	1056	-	clock	
	Pulse width	THp	2	128	200	clock	
Vertical sync. signal	Cycle	Tv	628	666	768	line	
	Pulse width	TVp	2	4	6	line	
Horizontal display period		THd	800	800	800	clock	
Hsync-Clock phase difference		THc	10	-	Tc-10	ns	
Vertical data start position		TVs	23	23	23	line	
Hsync-Vsync phase difference		TVh	0	-	TH-THp	clock	

Note) In case of lower frequency, the deterioration of display quality, flicker etc., may be occurred

7-2. Horizontal display position and data enable signal

The horizontal display position is determined by ENAB signal and the input data corresponding to the rising edge of ENAB signal is displayed at the left end of the active area.

Parameter		Symbol	Min.	Typ.	Max.	unit	Remark
Enable signal	Setup time	Tes	5	-	Tc-10	ns	
	Pulse width	Tep	2	800	Th-10	clock	
Hsync-Enable signal phase difference		THE	58	88	170	clock	【Note1】 

【Note1】 Please do not use the time of “The=91”.

Note) When ENAB is fixed “Low”, the display starts from the data of C88(clock) as shown in Fig.2. Be careful that the module does not work when ENAB is fixed “High”.

7-3. Vertical display position

The vertical display position, Tvs, is fixed "23" (line).

74. Input Data Signals and Display Position on the screen

Display position of input data (H, V)

(Outgoing light side view)

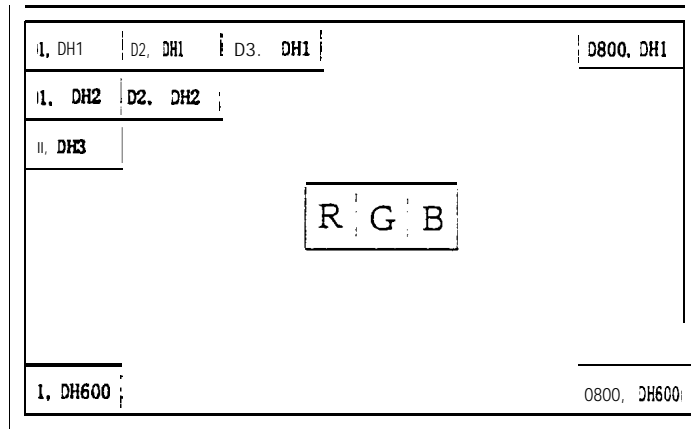

12 o'clock direction

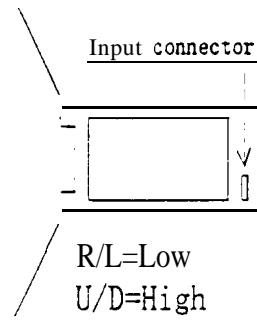

8. Input Signals, Basic Display Colors and Gray Scale of Each Color

	Colors & Gray scale	Data signal																	
		GrayScale	RO	R1	R2	R3	R4	R5	GO	G1	G2	G3	G4	G5	BO	B1	B2	B3	B4
Basic Color	Black	-	0	0	0	0	0	0	0	0	0	0	0	0	0	0	0	0	0
	Blue	-	0	0	0	0	0	0	0	0	0	0	0	0	1	1	1	1	1
	Green	-	0	0	0	0	0	0	1	1	1	1	1	1	0	0	0	0	0
	Cyan	-	0	0	0	0	0	0	1	1	1	1	1	1	1	1	1	1	1
	Red	-	1	1	1	1	1	1	0	0	0	0	0	0	0	0	0	0	0
	Magenta	-	1	1	1	1	1	1	0	0	0	0	0	0	1	1	1	1	1
	Yellow	-	1	1	1	1	1	1	1	1	1	1	1	1	0	0	0	0	0
	White	-	1	1	1	1	1	1	1	1	1	1	1	1	1	1	1	1	1
Gray Scale of Red	Black	GSO	0	0	0	0	0	0	0	0	0	0	0	0	0	0	0	0	
	↑	GS1	1	0	0	0	0	0	0	0	0	0	0	0	0	0	0	0	
	Darker	GS2	0	1	0	0	0	0	0	0	0	0	0	0	0	0	0	0	
	↑	↓				↓					↓						↓		
	↓	↓				↓					↓						↓		
	Brighter	GS61	1	0	1	1	1	1	0	0	0	0	0	0	0	0	0	0	
	↓	GS62	0	1	1	1	1	1	0	0	0	0	0	0	0	0	0	0	
	Red	GS63	1	1	1	1	1	1	0	0	0	0	0	0	0	0	0	0	
Gray Scale of Green	Black	GSO	0	0	0	0	0	0	0	0	0	0	0	0	0	0	0	0	
	↑	GS1	0	0	0	0	0	0	1	0	0	0	0	0	0	0	0	0	
	Darker	GS2	0	0	0	0	0	0	0	1	0	0	0	0	0	0	0	0	
	↑	↓				↓					↓						↓		
	↓	↓				↓					↓						↓		
	Brighter	GS61	0	0	0	0	0	0	1	0	1	1	1	1	0	0	0	0	
	↓	GS62	0	0	0	0	0	0	0	1	1	1	1	1	0	0	0	0	
	Green	GS63	0	0	0	0	0	0	1	1	1	1	1	1	0	0	0	0	
Gray Scale of Blue	Black	GSO	0	0	0	0	0	0	0	0	0	0	0	0	0	0	0	0	
	↑	GS1	0	0	0	0	0	0	0	0	0	0	0	1	0	0	0	0	
	Darker	GS2	0	0	0	0	0	0	0	0	0	0	0	0	1	0	0	0	
	↑	↓				↓					↓						↓		
	↓	↓				↓					↓						↓		
	Brighter	GS61	0	0	0	0	0	0	0	0	0	0	0	0	1	0	1	1	
	↓	GS62	0	0	0	0	0	0	0	0	0	0	0	0	0	1	1	1	
	Blue	GS63	0	0	0	0	0	0	0	0	0	0	0	0	1	1	1	1	

0: Low level voltage, 1: High level voltage

Each basic color can be displayed in 64 gray scales from 6 bit data signals. According to the combination of total 18 bit data signals, the 262,144-color display can be achieved on the screen.

9. optical characteristics

Ta=25°C, Vcc=+5.0V

Parameter	symbol	Condition	Min.	Typ.	Max.	unit	Remark	
Viewing angle range	Horizontal	$\theta > 10$	35	-	-	Deg.	【Note1,4】	
	Vertical		$\theta 11$	30	-	-		Deg.
			$\theta 12$	10	-	-		Deg.
Contrast ratio	C R	$\theta = 0^\circ$	100	-	-		【Note2,4】	
Response time	Rise		τr	-	20	-	m s	【Note3,4】
	Decay		τd	-	40	-	m s	
Transmissivity	Tr		-	6.0	-	%	【Note4,5】	
Shift of Chromaticity (white)	Δx		-0.027	+0.003	+0.033			【Note5,6】
	Ay	0.000	+0.030	+0.060				

※The measurement shall be executed 30 minutes after lighting at rating.

The optical characteristics shall be measured in a dark room or equivalent state with the method shown in Fig.3 below.

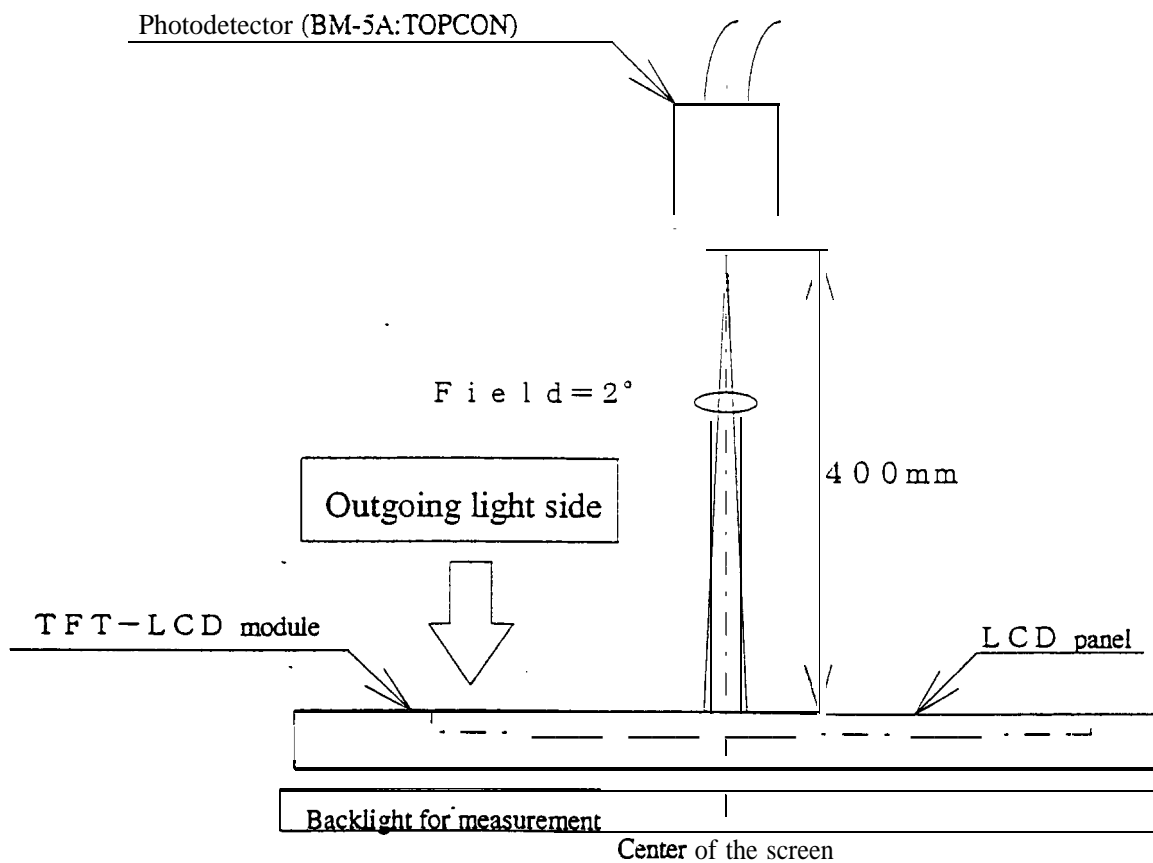
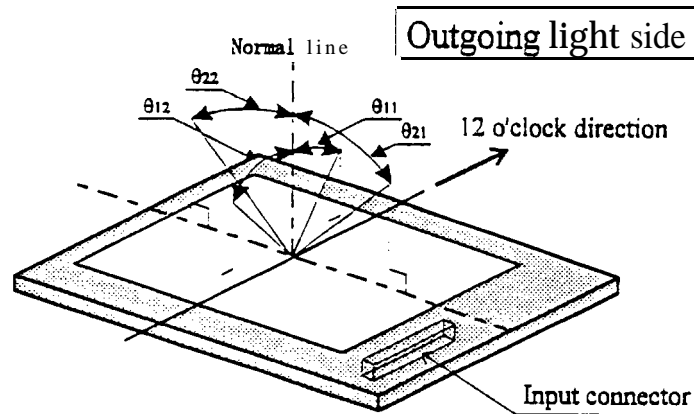

Fig.3 optical characteristics measurement method

【Note1】 Definitions of viewing angle range:



【Note2】 Definition of contrast ratio:

The contrast ratio is defined as the following.

$$\text{Contrast Ratio (CR)} = \frac{\text{Luminance (brightness) with all pixels white}}{\text{Luminance (brightness) with all pixels black}}$$

【Note3】 Definition of response time:

The response time is defined as the following figure and shall be measured by switching the input signal for “black” and “white” .

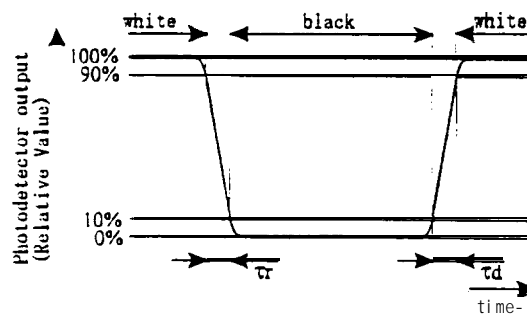

【Note4】 This shall be measured at center of the screen.

【Note5】 Definition of transmissivity:

Transmissivity is defined as follows.

$$T_r = \frac{\text{Luminance of transmitted light}}{\text{Luminance of incident light}} \times 100(\%)$$

(Power source is not applied)

【Note6】 Chromaticity shift is the difference of the chromaticity of the light source and that of the outgoing light through the module.

10. Display Quality

The display quality of the color TFT-LCD module shall be in compliance with the Incoming Inspection Standard.

11. Handling Precautions

11-1) Be **sure** to insert the cable into **the** connector or take out of the connector after turning off the power supply on the system side.

11-2) precautions in mounting

A) When installing the module, be sure to **fix** the module on the same plane, taking care not to warp or twist the module.

B) Since the polarizer is made of soft material, please take care not to scratch the surface. Protective laminated film is attached on the panel surface to protect from scratches or dirt. It is recommended that the laminated film is peeled off, just before the use, with strict attention to electrostatic charges.

※) Precautions when **peeling** off the laminated film:

I) Working environment

When the laminated film is **peeled** off, there may be cases that some particles like dust are stuck on the panel by electrostatic charges or the TFT panel is damaged by electrostatic discharge, so the following working environment is recommended.

- (a) **Floor:** Anti-electrostatic treatment more than $1M\Omega$ on the floor.
- (b) **Spread an** adhesive mat at a doorway in the clean room.
- (c) Humidity: 50% to 70%, Temperature: 15 °C to 27°C
- (d) Worker needs to wear the **anti-electrostatic** shoes, anti-electrostatic workwear, anti-electrostatic gloves and earth band.

II) How to work

- (a) Keep the distance between **the** module and the heated ionized air blower within 20cm. **The** module shall be well blown to the wind of the blower. (Fig.①)
- (b) Attach an adhesive tape to the corner of the laminated film near the heated ionized air blower. (Fig.②)
- (c) Peel the laminated film pulling the adhesive tape to your side. It is important that it takes more than 5 seconds to peel off the laminated film.
- (d) The module after **peeling** the laminated film must be moved to next work immediately without getting dust.
- (e) The way to remove 'dust' from the surface of the polarizer
 - Blow it off by nitrogen blow that is taken measures against electrostatic charges. Ionized air gun is recommended.
 - Since polarizer is easily damaged, In unavoidable case, wipe it carefully by the cloth like a **wiper** for lens. **breathing** on

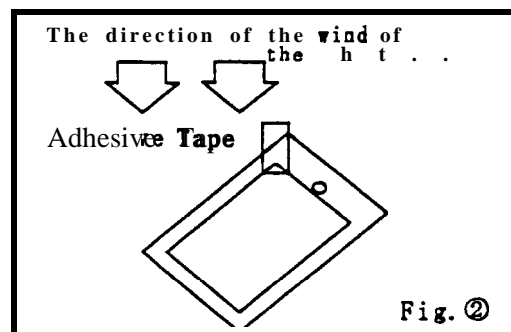
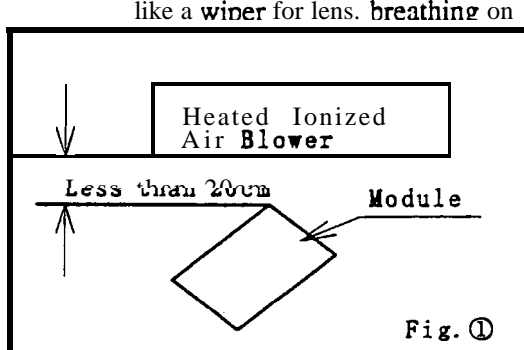

1 1-3) Others

- A) Wipe off water drop immediately. **Long** contact with water may cause discoloration or spots.
- B) When the panel surface is soiled, wipe it with absorbent cotton or other soft **cloth**.
- C) Since the panel is made of glass, it may **break** or crack if dropped or bumped on hard surface.
Handle with care.
- D) Since **CMOS LSI** is used in this module. take care of static electricity and ground your body when handling.
- E) **Observe** all other precautionary **requirements** in handling components.

12. Packing form

- 1) Piling number of cartons : **MAX 7**
- 2) Package quantity in one croon : 10 pcs
- 3) Carton size : 413 (W)×288 (H)×351(D)mm
- 4) **Total** mass of one carton filled with full modules : 6500 g

Packing form is shown in Fig.4

13. **eliability** test items

No	Test item	Conditions
1	High temperature storage test	Ta=60°C 240h
2	Low temperature storage test	Ta=-25°C 240h
3	High temperature & high humidity operation test	Ta=40°C ; 95%RH 240h (No condensation)
4	High temperature operation test	Ta=50°C 240h (The panel temp. must be less than 60°C)
5	Low temperature operation test	Ta=0°C 240h “
6	Vibration test (non- operating)	Frequency : 10~57Hz/Vibration width (one side) :0.075mm : 58~500Hz/Gravity:9.8m/s ² Sweep time : 11 minutes Test period :3 hours (1 hour for each direction of X,Y,Z)
7	Shock test (non- operating)	Max. gravity : 490m/s ² Pulse width : 1 1ms, half sine wave Direction : ±X, ±Y, ±Z once for each direction.

[Result Evaluation Criteria]

Under the display quality test conditions with normal operation state, these shall be no change which may affect practical display function.

14. Others

1) Lot No. Label:

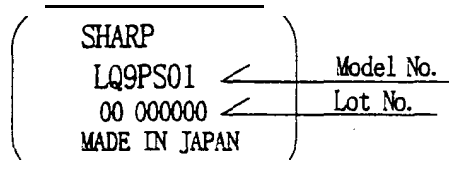

- 2) Adjusting volume have been set optimally before shipment, so do not change any adjusted value.
If adjusted value is changed. the specification may not be satisfied.
- 3) Disassembling the **module** can **cause** permanent damage and should be strictly avoided.
- 4) Please be careful that image **retention** may occur when a **fixed** pattern is displayed for a long time.
- 5) If any problem occurs in relation to the description of this specification, it shall be resolved **through** discussion with spirit of cooperation.

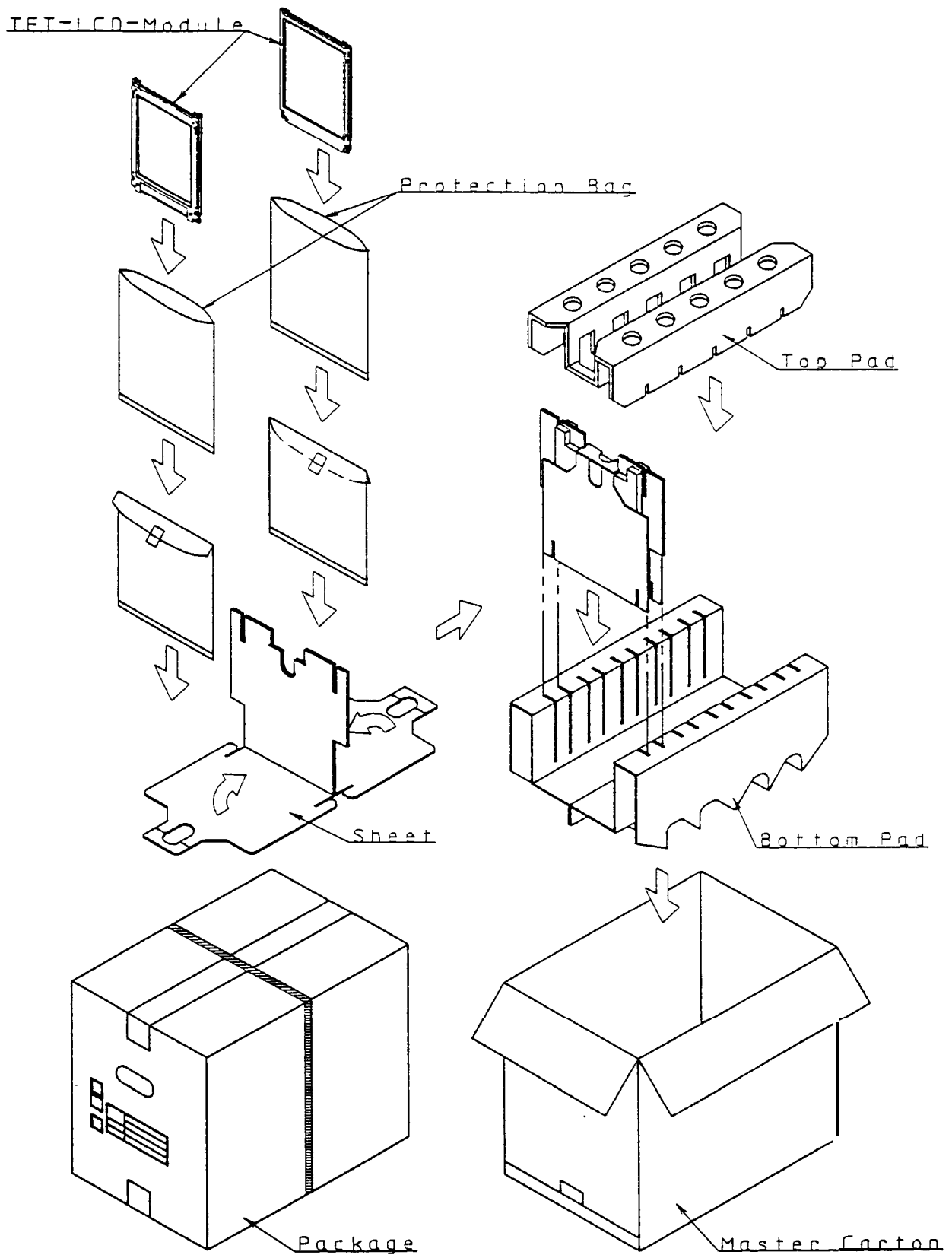

Fig. 4 Packing form

